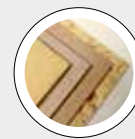

## KNIFE RING WASHER

**WMG****BEST IN CLASS FOR:**

WOOD BASED PANELS:

PB/SPB

OSB/LSB/FOSB

The machine is a high-efficiency washing machine, specifically designed for cleaning knife rings, combining power and precision in a fully automated process.

**TECHNICAL FEATURES AND BENEFITS**

- High-pressure system with water jets up to 160 bar, ensuring deep and effective cleaning
- Integrated cleaning brush, for removing persistent residues
- Wastewater collecting tank, ensuring a clean and organized process
- Wastewater recovery system, allowing for optimized water consumption and environmental sustainability
- High-pressure piston pump (HP system), providing reliable and powerful pumping performance
- Compressed air drying system, eliminating water residues and speeding up processing times
- Fully sealed structure, preventing water dispersion for a cleaner and safer work environment
- Water recovery option, optimizing water usage and reducing waste
- Optional water heating system, improving cleaning efficiency, especially in demanding applications
- Fast and simplified installation, thanks to pre-wiring and pre-testing before delivery, minimizing setup time

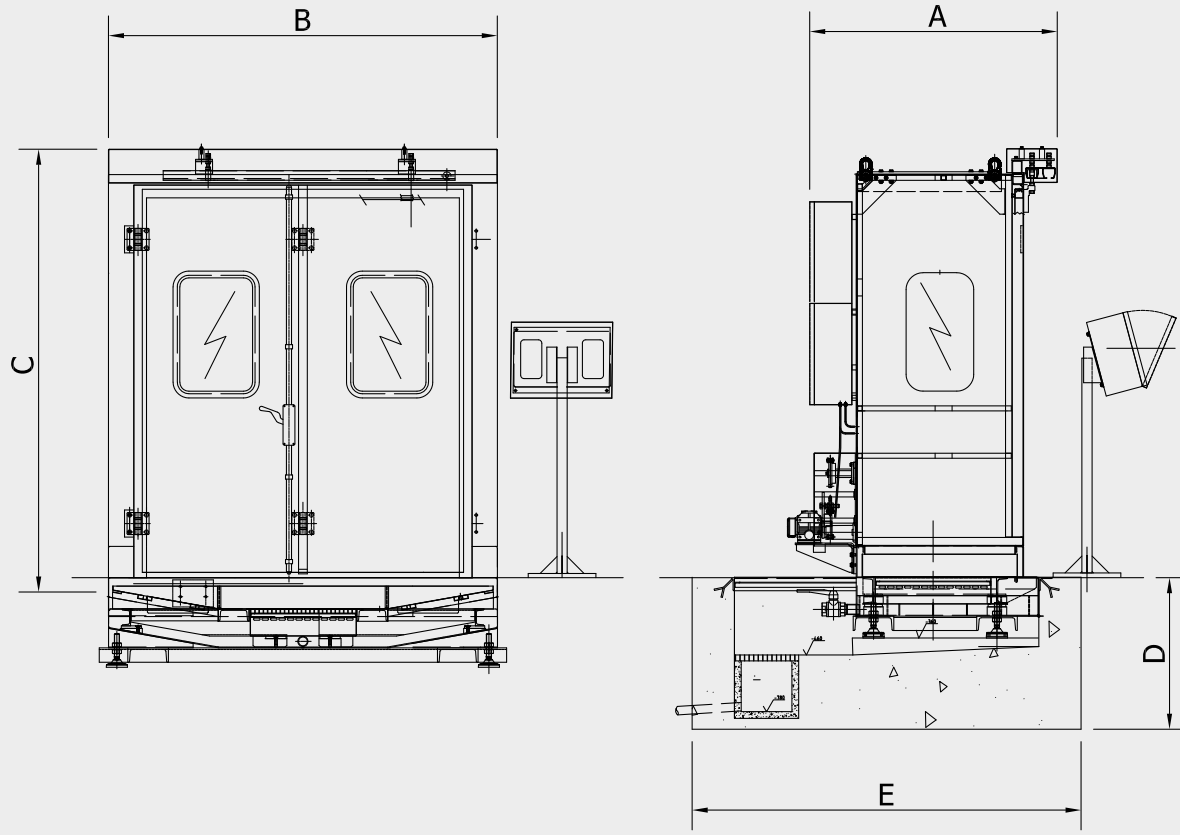

MODEL	OVERALL DIMENSIONS mm				
	A	B	C	D	E
WMG 490	1250	2300	2700	900	2300
WMG 690	1450	2300	2700	900	2300
WMG - Customized	***	***	***	***	***

TECHNICAL DATA	
CYCLE TIME	30 Min / 1 Ring
WATER REQUIREMENTS	2400 l/h
HIGH PRESSURE	160 bar
TOTAL INSTALLED POWER	18 kW

\*\*\*According to customer needs