

ROLLER DISCHARGE – RDG



The machine is a roller system designed for log cleaning and pre-processing, ensuring a steady and continuous material flow to the next processing stages

TECHNICAL FEATURES

- Steel star-shaft structure available with interconnected disks (RDG) for efficient bark removal
- Maintenance-free bearings and reinforced transmission, ensuring long operational life
- Optimized design to minimize friction and wear, extending component durability
- Adjustable working speed, with one or multiple independent motors for enhanced material flow control
- Reversible material flow, providing greater flexibility and adaptability to the production line

BENEFITS

- Efficient removal of bark, debris, and even snow in winter, ensuring optimal log processing in all conditions
- Consistent and continuous material flow, improving chipping line efficiency and preventing blockages
- Low maintenance, thanks to durable components designed for long-term intensive use
- Maximum flexibility, with adjustable speeds and customizable configurations based on wood type
- Easy integration into existing production lines, thanks to its modular design and customization options

BEST IN CLASS FOR:

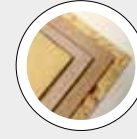

WOOD BASED PANELS:

PB/SPB

OSB/LSB/FOSB

MDF/HDF

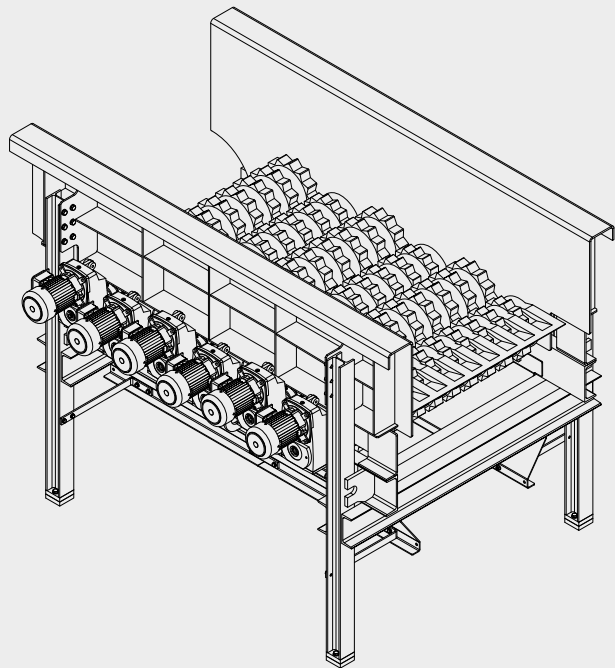
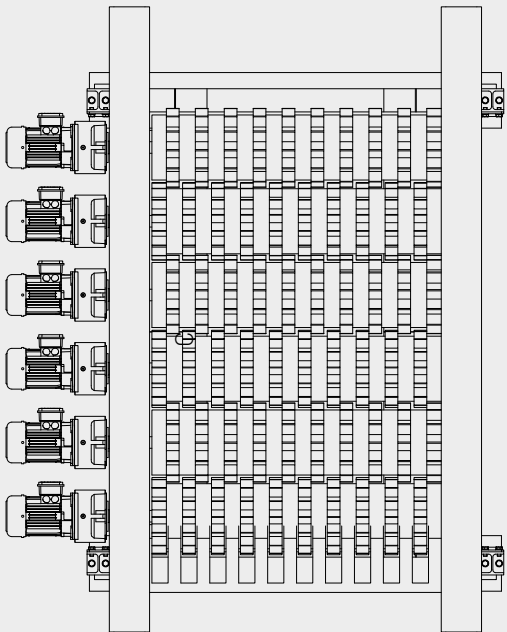
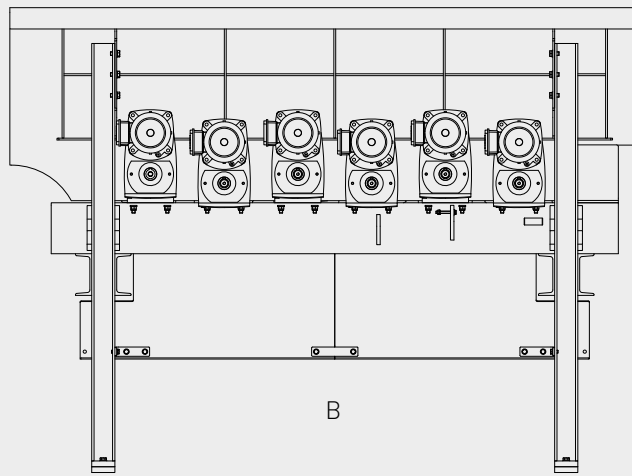
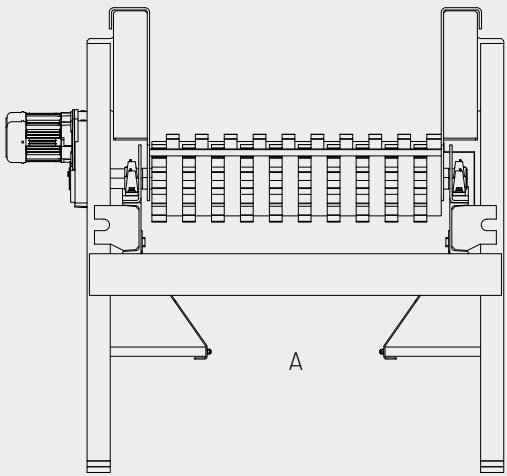

MODEL	OVERALL DIMENSIONS mm ***			
	A	B	C	N° rollers
RDG**	800 ÷ 1650	5000 ÷ 21000	800 ÷ 1600	10 ÷ 38

MODEL	CAPACITY m ³ /h Sob	POWER kW	WEIGHT Kg
RDG**	30 ÷ 400	***	5000 ÷ 20000

***According to customer needs

**According to dimensions