

DRY MILLS
CENTRIFUGAL MILLS – MCG



This machine is used for refining dry wood flakes, making them suitable for surface and core layers in particleboard, as well as for multilayer products such as LSB (Laminated Strand Board) and OSB (Oriented Strand Board).

TECHNICAL FEATURES

- Refining mills for dry flakes suitable for surfaces and core layers in particleboard production or multilayer LSB/OSB product
- Equipped with standard screen support ring for Conidur screen of various different hole according to the required particles
- Oil lubrication system for main bearings
- Feeding door provided with air cleaner to reject heavy pollutants.

BENEFITS

- Fast replacement of the ring screen
- Heavy-duty ring construction to avoid distortion and oval shaped
- Grinding track according to raw material.

BEST IN CLASS FOR:

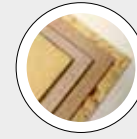

WOOD BASED PANELS:

PB/SPB

OSB/LSB/FOSB

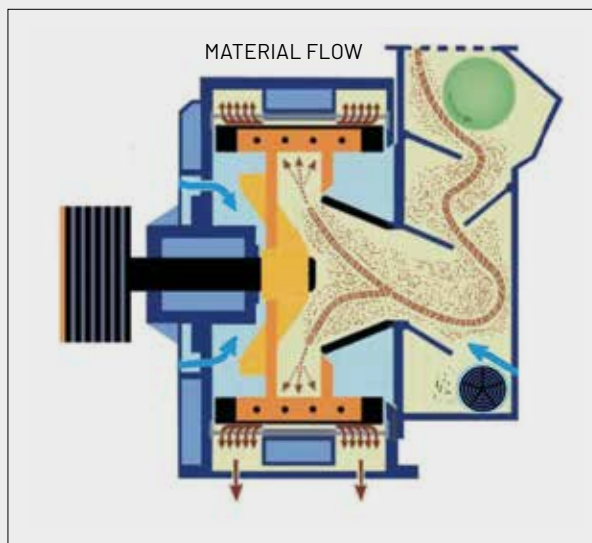
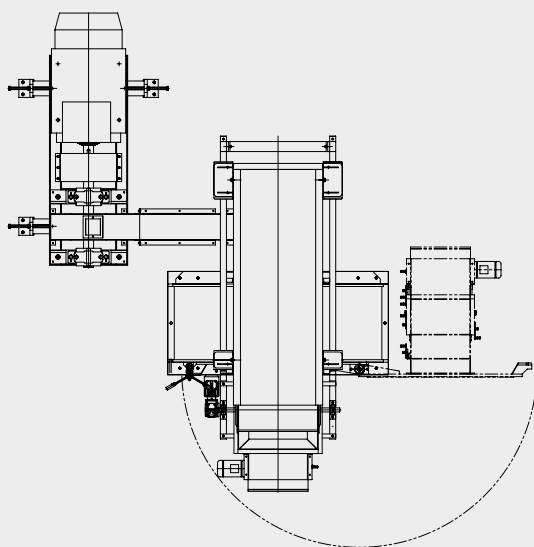
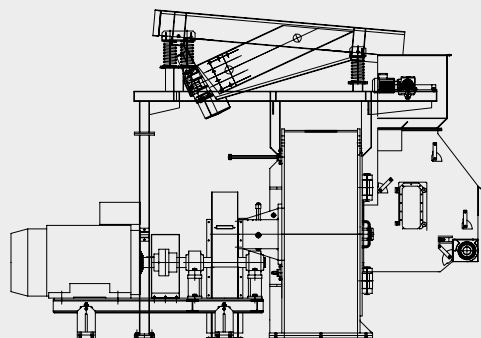
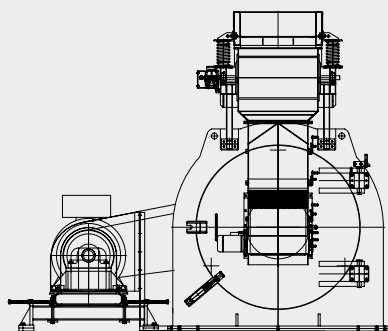

MODEL	ROTOR DIAMETER mm	GRINDING SECTORS WIDTH mm	SCREENS WIDTH mm	WEIGHT WITHOUT MAIN MOTOR kg	RECOMMENDED MOTOR kW
MCG 510	1000	225	2 x 160	3000	132/160
MCG 610	1200	225	2 x 193	4000	160/200
MCG 710	1400	265	2 x 210	4700	200/250
MCG 760	1500	288	2 x 223	5700	250/315

