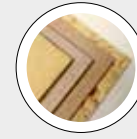

CHIPPERS

**BOARD BREAKER OFFLINE - BBO****BEST IN CLASS FOR:**

WOOD BASED PANELS:

MDF/HDF

PB/SPB

OSB/LSB/FOSB



The machine is designed to reduce rejected boards as well as cutouts of initial and final board. It is ideal for MDF, OSB and PB boards.

**TECHNICAL FEATURES**

- Reliable breaking of rejected boards with different size and thickness
- Blockages are avoided thanks to the high torque power and ability in breaking at high feed speed
- Reduced installed power thanks to the dual motor design
- Very strong and reliable in the long term, low operating costs thanks to the simplified maintenance
- Replaceable wear components to protect the essential parts of the machine
- Boards infeed controlled by integrated roller way
- Interchangeable cutting tools
- Perforated and divided screen for an easy replacement

**BENEFITS**

- Shredding of waste panels of various sizes and thicknesses
- Robust structure for long-term reliability
- Energy-efficient size reduction
- Wear parts are protected and easy to replace
- Reduced operating costs thanks to simplified maintenance

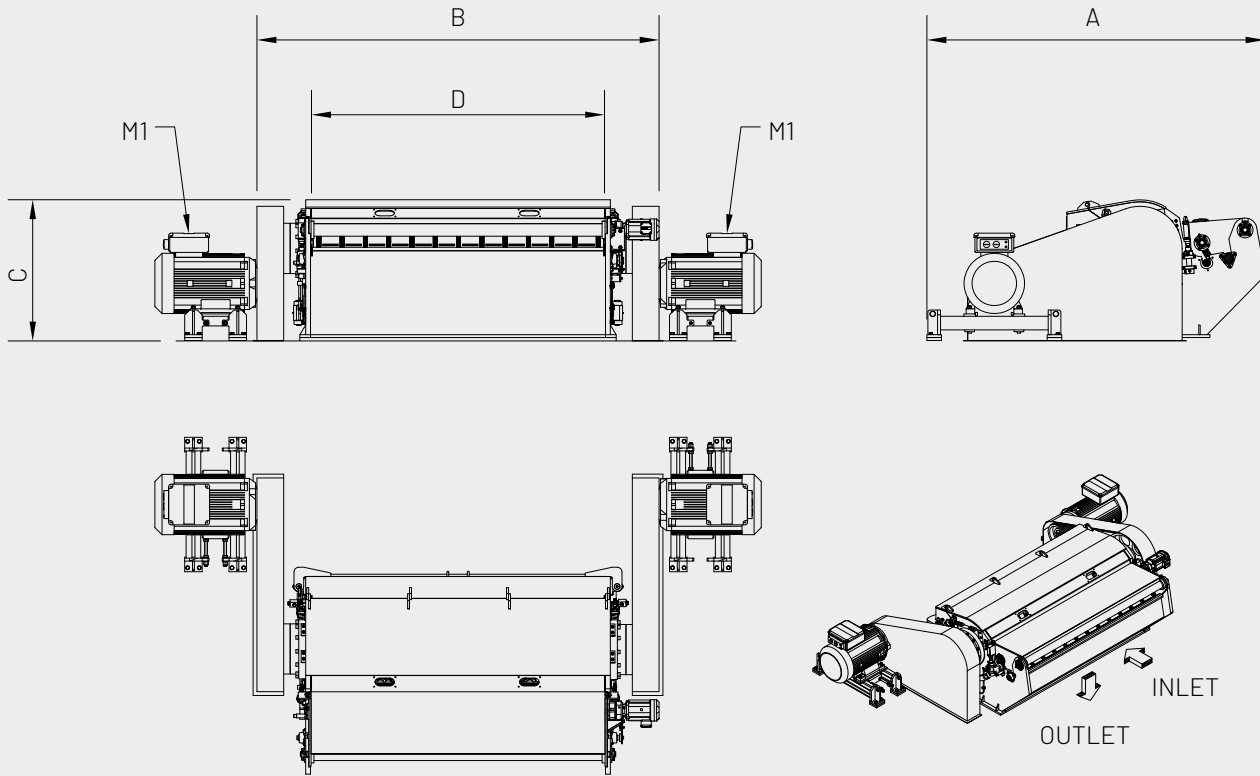

M1 = VIBRATING MOTOR

MODEL	OVERALL DIMENSIONS mm			
	A	B	C	D (infeed width)
MPG 2000	3500	3100	1500	2000
MPG 3000	3500	4100	1500	3000

MODEL	TECHNICAL DATA				
	INFEED SPEED mm/s	POWER M1 kW	ROTOR Ø mm	ROTOR LENGHT mm	WEIGHT kg
MPG 2000	100 ÷ 2000	1x250	746	2090	12000
MPG 3000	100 ÷ 2000	2x200	746	3090	15000